

EDGE CLIP DEMOUNTABLE STICK BUILT WALL SYSTEM STEP BY STEP INSTALLATION INSTRUCTIONS

| STEP | DESCRIPTION |
|------|----------------------------------|
| 1 | CEILING RUNNER |
| 2 | BASE TRACK |
| 3 | STEEL STUDS |
| 4 | STEEL FRAMING AT DOORS |
| 5 | STEEL FRAMING AT WINDOWS |
| 6 | PANEL LAYOUT AND CORNERS |
| 7 | VINYL COVERED PANEL INSTALLATION |
| 8 | ALUMINUM DOOR FRAMES |
| 9 | ALUMINUM WINDOW FRAMES |
| 10 | FINISHING TOUCHES |

1. CEILING RUNNER

1. Where to start...

Determine if the layout is to follow a building grid such as the T-bar ceiling or the window mullions. Mark on ceiling where the ceiling runner is to be located.

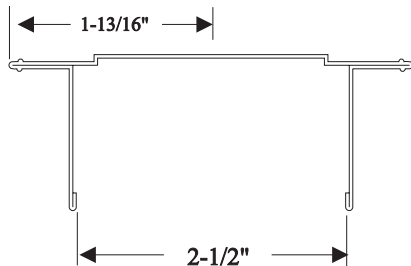

2. Mark for ceiling runner

Allow 1 13/16" from the centreline of ceiling runner so you can see the mark when you install the track. If layout does not follow a building grid, check to see if the room measurements are inside measurements or center to center.

Note:

Since you must offset your marked layout on the ceiling 1 13/16" from the centreline of the wall, ALWAYS make sure you offset to the same side and put a small "X" on the side of the mark that will be covered by the ceiling runner.

3. Installing ceiling runner

Because you have to hold a 10' length overhead, it will take an extra person to help hold the runner steady while fastening it to the ceiling. The ceiling runner is continuous over doors and windows. Cut the ceiling runner to required lengths with tin snips. Fasten the ceiling runner to the T-bar using the L-clips.

Fastening to drywall

1-1/4" Drywall screws

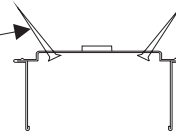

You can use toggle bolts to fasten the ceiling runner to a drywall ceiling, but two 1 1/4" drywall screws angled away from each other will do the job.

L-clips are used to prevent grid system damage.

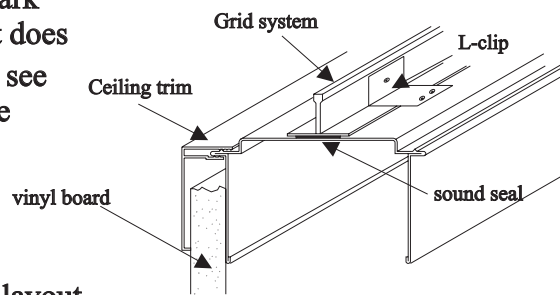
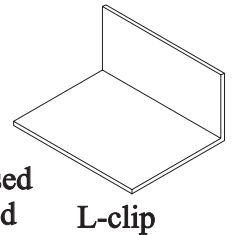

Section showing finished ceiling runner assembly with ceiling trim and board in place. The ceiling trim is designed to snap onto the ceiling runner directly.

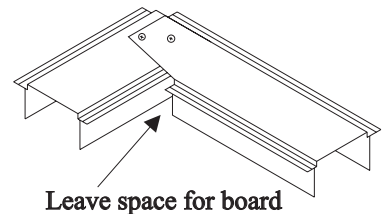

Ceiling runner at corner

For added stability at corners cut, overlap, and screw together runners as shown.

Material requirements

For ease of identification, all partition components are illustrated on the back page for quick reference.

Sound and light seals

The PS-350 system outperforms standard walls in providing sound privacy. To obtain maximum benefit it is necessary to use closed-cell foam seals to fill in the spaces between the ceiling, ceiling runner, floor, base track, and wall junctions. Attach seals to the runner or track before installation. It is very important to have the sound seal even when applied over carpet.

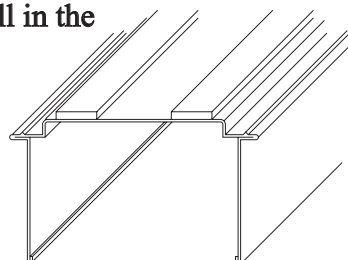

Sound seal

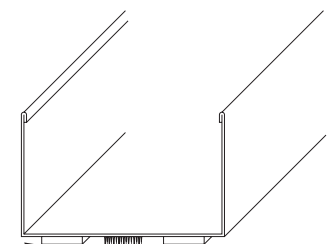

Velcro hook tape: used to install floor track over carpet which has a loop pile.

2. BASE TRACK

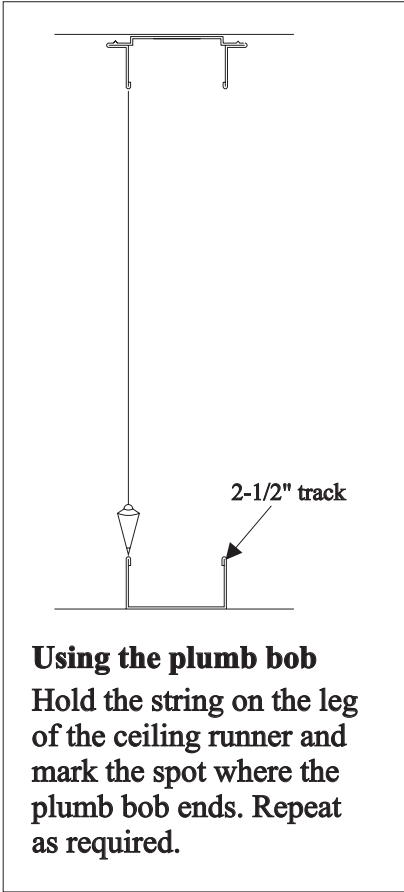

Using the plumb bob
 Hold the string on the leg of the ceiling runner and mark the spot where the plumb bob ends. Repeat as required.

Installing base track

After the ceiling runner is installed, mark the location for the base track by plumbing down from the ceiling runner using a plumb bob (see drawing) or laser level. Remember to apply the velcro tape and sound seal to the track before installing.

The base track runs continuous except at door openings:

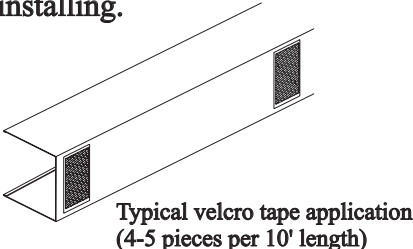

At door openings, terminate the base track so that the track ends at the door and frame width rough opening.

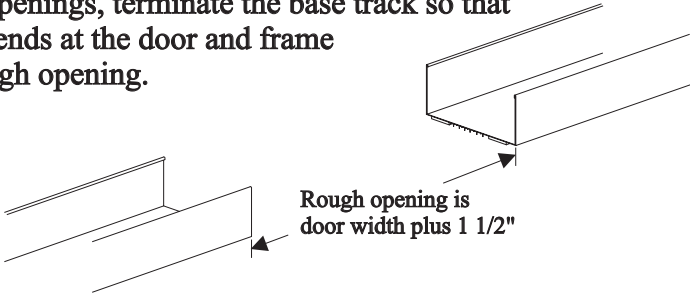

Track spacing at "T" intersection

End caps

At the exterior corner the flanges of the track must meet at the corner:

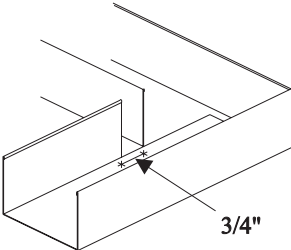

Cut out the base track as shown. The 3/4" space accommodates installation of panels later.

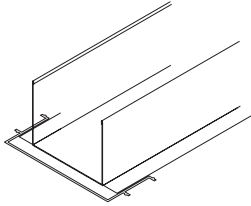
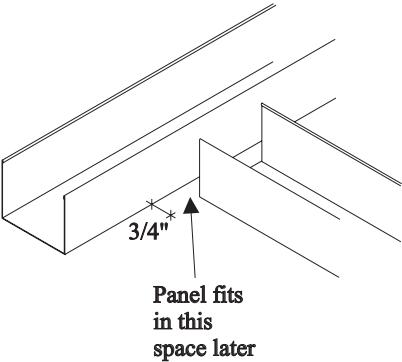

Surface end cap

3. STEEL STUDS

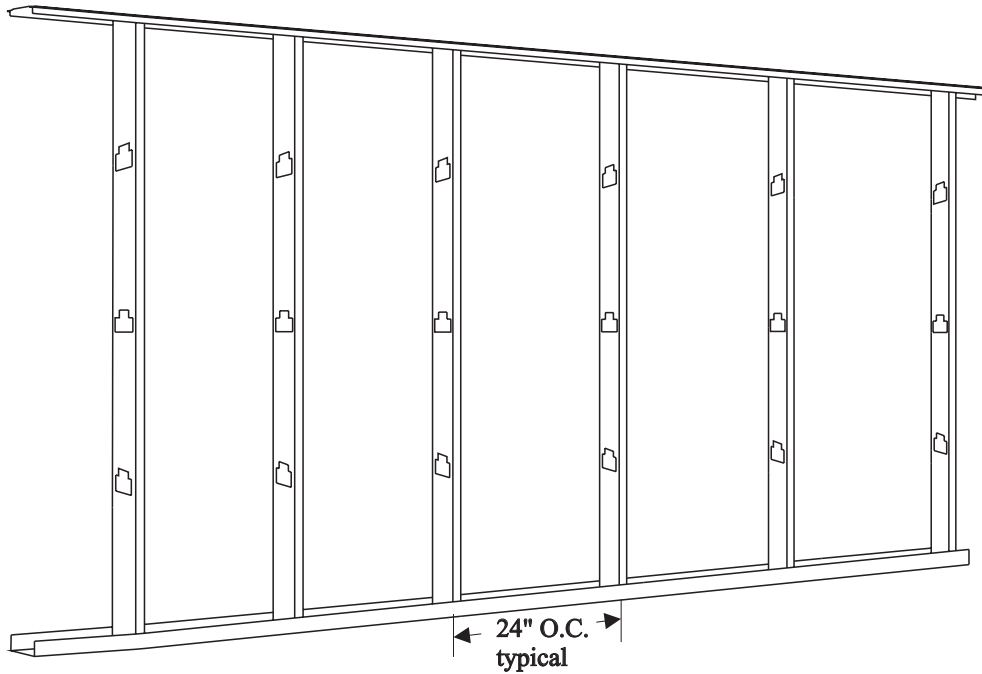

Installing studs

The PS-350 studs are made to friction fit into the ceiling runner and the base track. Just put the studs in sideways at an angle, push them up perpendicular and twist them until they are tight into the ceiling runner. Level and secure with screws at top and bottom.

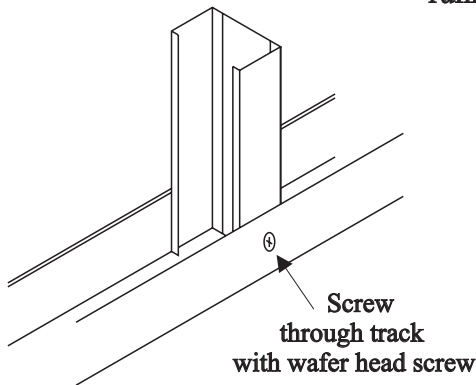

Studs at intersections

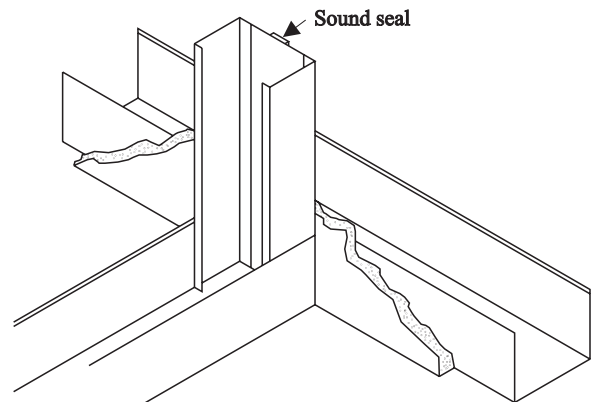

Studs at wall starts

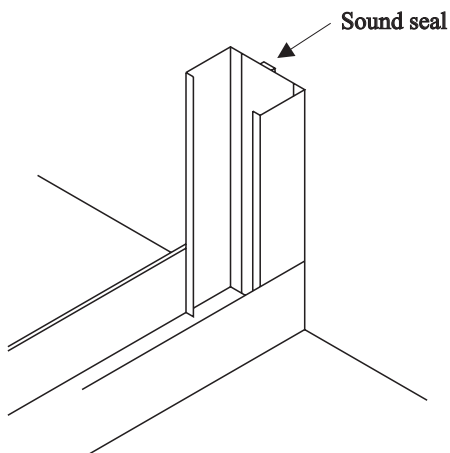

Studs at corners

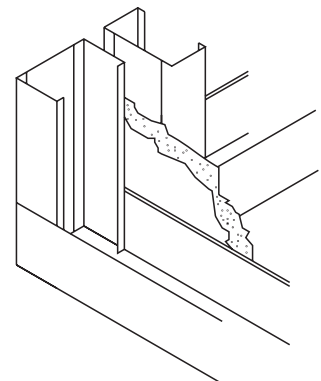

4. STEEL FRAMING AT DOORS

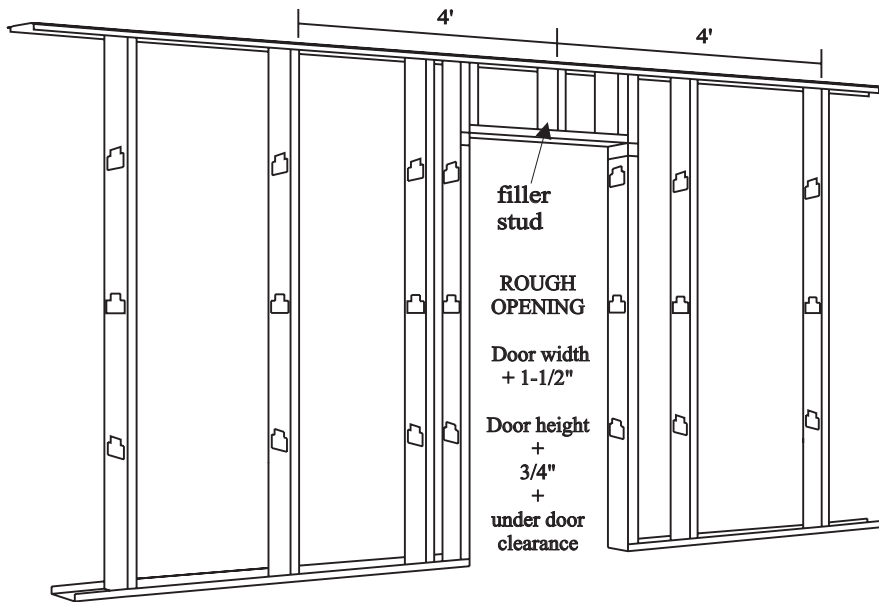

Rough opening for partial height door
Cut out a rough header as shown in the following illustration. Install the header with the cutout legs pointing downwards. Add a filler stud for extra support.

5 Steps To Install Steel Studs

1. Fasten hinge side stud to the base track
2. Plumb hinge side stud and fasten to the ceiling runner
3. Measure over to jamb side stud at floor and fasten stud to track
4. Measure over to jamb stud at ceiling and fasten stud to ceiling runner
5. If it is a partial height door, cut rough header from base track and then install level, with legs down, at door height plus 3/4" above the finished floor plus underdoor clearance.

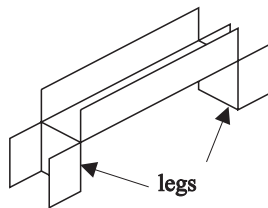

Rough header:

Cut out from a piece of 2 1/2" track to use as a header in the rough opening for the partial height door.

Fasten rough header to studs using 1/2" wafer head screws. Header is set at door height plus 3/4" plus under door clearance.

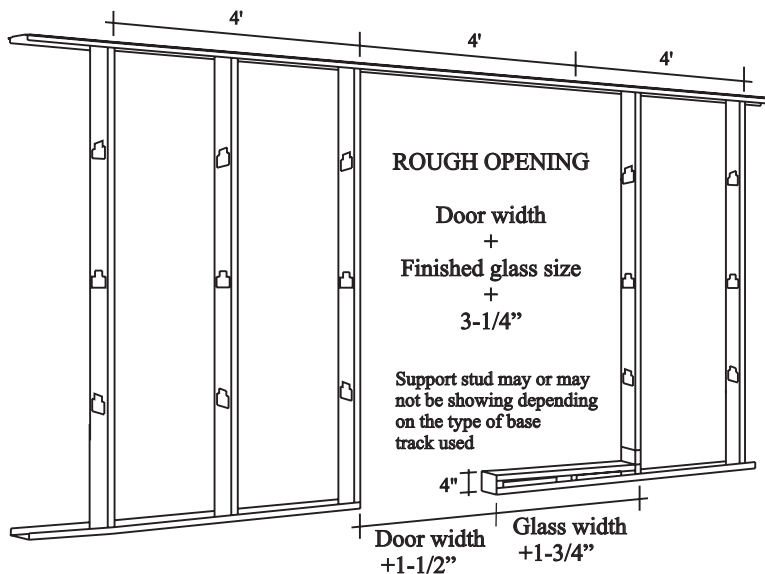

Rough framing for full height door with sidelite

The rough opening should be the door width plus the finished glass width plus 3-1/4". The rough sill should be installed 4" above the floor as illustrated.

5. STEEL FRAMING AT WINDOWS

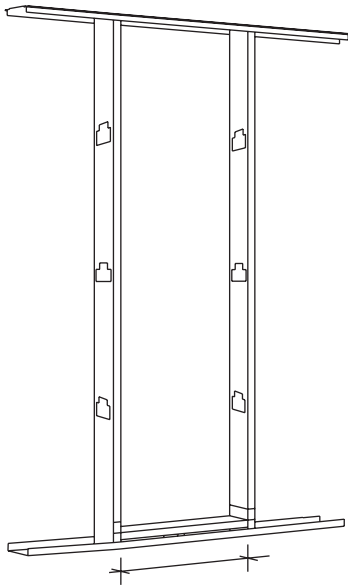

ROUGH OPENING = Finished Opening width + 1-1/4"

Framing for full height windows

Studs at a full height window opening are plumbed in a similar manner as for studs at a door opening. First, plumb and fasten one side and then the other. The rough sill (at the bottom of the window) is made from a piece of base track. This rough sill is fastened to the studs, leveled at 4" above the floor.

In order to accommodate variations in the floor level, the rough sill is friction-fitted into place and then leveled with a spirit level.

Measurements to the floor are averaged and then the rough sill is installed with 1/2" wafer head screws. Make sure that the rough sill is level.

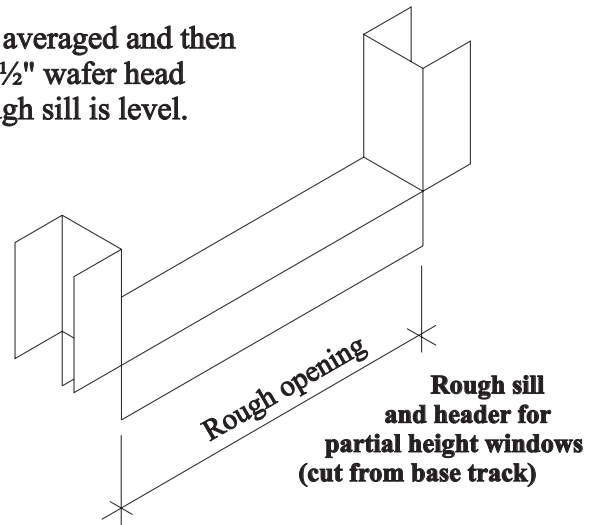

Rough sill and header for partial height windows (cut from base track)

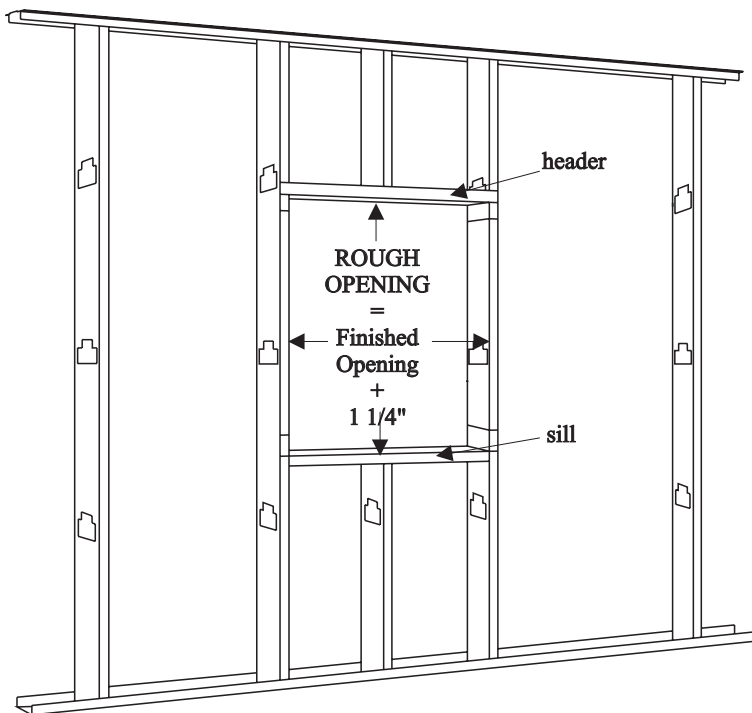

Framing for partial height windows

Partial height windows or wicket openings are installed using base track for the rough sill and rough header. Vertical studs are plumbed and fastened using the 5 step method. For window openings over 24", extra studs are required above and below the opening. Make sure the sill and header are level before fastening to the jamb studs.

Rough opening size is finished window size plus 1 1/4" in both directions.

Continuous glazing

Where glazing is to be run continuously with a number of posts to divide up the glass into practical sizes, the rough sill is run continuously. No vertical studs are required for posts. The vertical posts are constructed later from the aluminum frames.

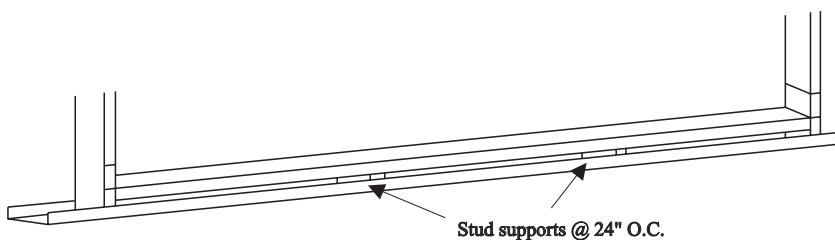

6. PANEL LAYOUT AND CORNERS

The correct panel layout:
If possible lay out the panels so that no panel is less than 2' wide. It is usually best to start at the corners with full panels and work towards existing walls and doorways.

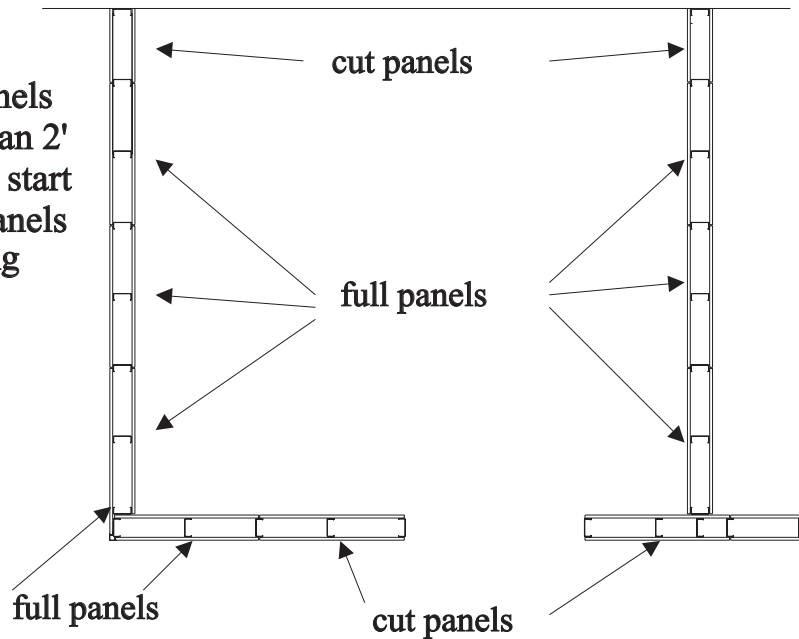

CORNER PIECES

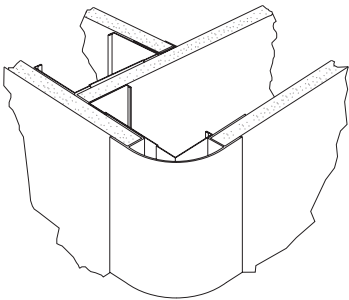

Round corner

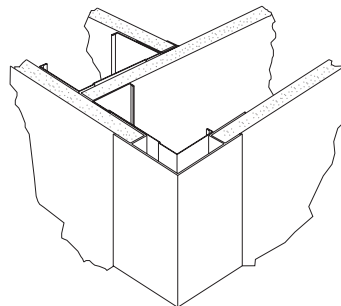

Square corner

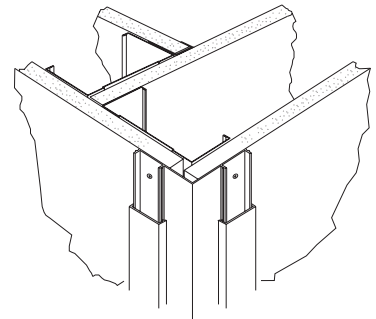

Surface corner

After installing the studs, the corner pieces are put in. Screw corner pieces into corner studs.

Note:
Surface mounted corners are installed AFTER wall panels are put in.

7. VINYL COVERED PANEL INSTALLATION

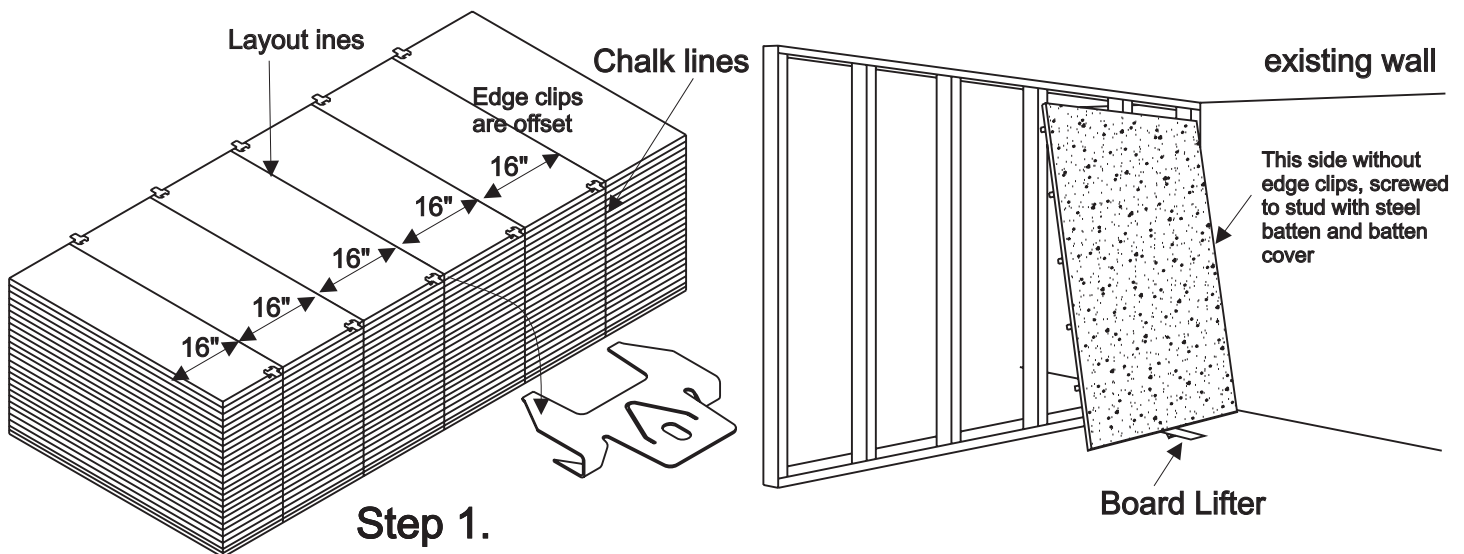

Step 1. Cut the sheet to slightly less than the floor to ceiling height. Lay out the back of a panel by drawing layout lines a 16" intervals. Lines can be carried down sides of stacked panels with a chalk line.

Step 2.

Locate clips above the line on one side and below on the opposite side. Staggered clip layout creates a tongue and groove panel joint.

Step 3.

Seat the clips with the Clip Driver provided. Do not damage panel edge.

Step 4.

Panels against an existing wall are not clipped on the side against the wall. This edge is screwed to the stud with a steel batten and PVC batten cover.

Screw top and bottom of sheet to tracks, with ordinary drywall screws.

Screw the edge clips on the final edge to the stud

7. VINYL COVERED PANEL INSTALLATION (CONTINUED)

Step 5.

Only one side of each panel is directly screw fastened. Special screws engineered for clip use have a small drill point and a wide thread to eliminate "strip-out" in light gauge framing.

Step 6.

Consecutive panels are clipped on both sides. The protruding tabs are fit between the stud and previous panel as shown. Tighten the joint with a floor leverage tool.

The clips on the free edge are screwed to the stud.

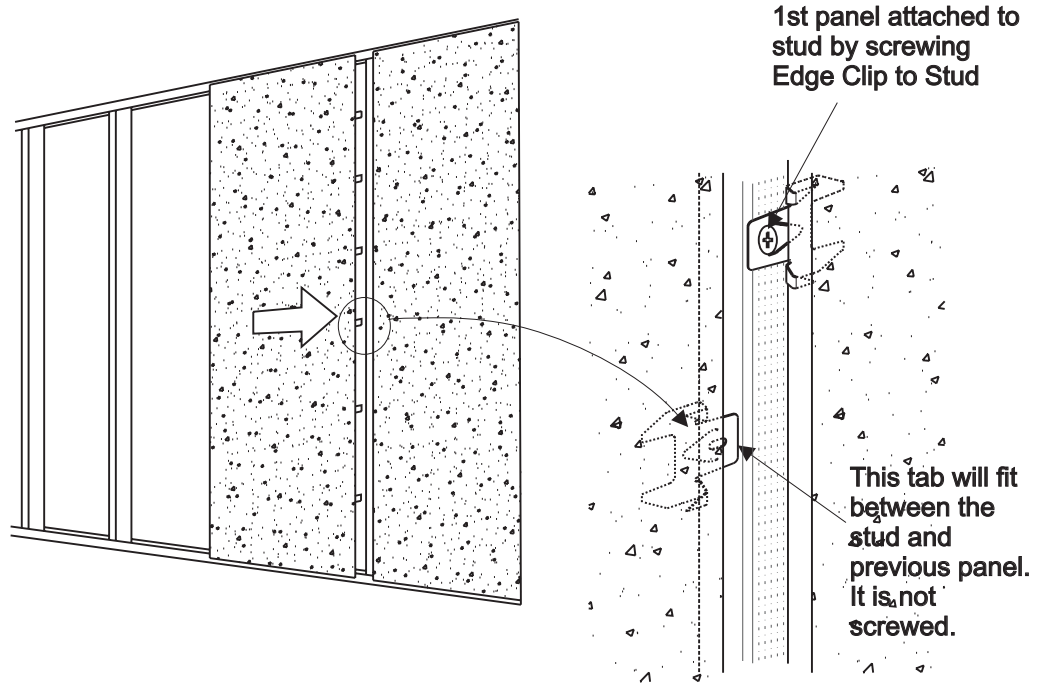

Allow the panels to adjust (lift) to accommodate the screw head

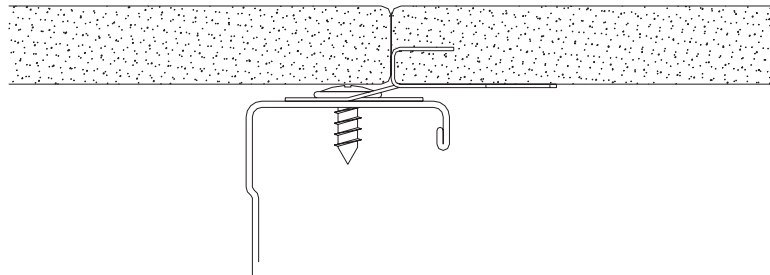

A few adhesive dabs on centre studs (between joints) can correct bowed panels and stiffen the wall.

Stagger joints on opposite sides of the wall when possible.

Step 7.

When the wall intersects another wall. The free edge is not clipped. It is screwed in place with a steel batten and cover.

Note: For increased sound control install PS-350 sound attenuation blanket between the stud after the board is installed on one side of the wall.

8. ALUMINUM DOOR FRAMES

NOTE: Header on Full height extends beyond verticals

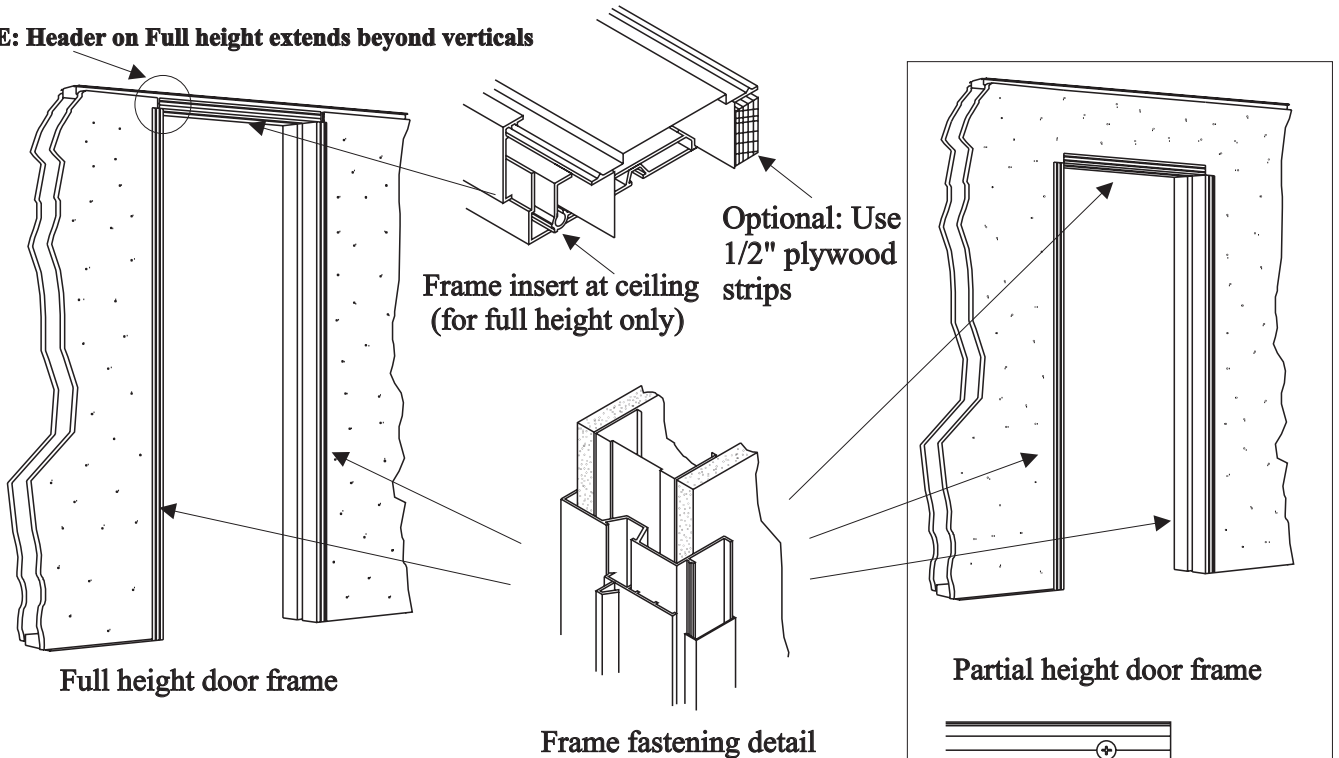

Installation Steps

1. Cut aluminum jambs so they are fairly tight to the rough header. Install hinge side aluminum jamb plumb and true fastening at top and bottom only. If less clearance is required, cut off bottoms accordingly.
2. Place second jamb in position, but do not fasten.
3. Cut aluminum header 3/8" longer than the door width and push tightly to the fastened jamb. Place header between jambs 3/8" down from tops of jambs (see illustration). Use a carpenter square from secured jamb to header and fasten header at ends.
4. Measure header length to space bottom of jambs and fasten second jamb. Door frame should now be plumb and square.
5. Secure frame both sides with drywall screws 8" O.C. using straight edge on jambs to ensure they remain straight while fastening.
6. Install door stop into header first.
7. Next, determine door swing and hinge locations for site notching of the plastic door stop. Mark the corresponding hinge locations and remove by cutting the plastic back to the notch guide line located on the underside of the stop. Snap out and install into the frame.
8. Do not install the strike side door stop until the door is hung and the strike plate location is established. Cut out for the strike plate by following the above procedure.
9. With the strike plate location known, center punch and drill out the aluminum frame to accept the nylon strike plate using a 1" hole saw. Cut out as per illustration. File any rough edges and install strike plate using self drilling flathead screws.
10. Install strike plate side door stop.
11. Install header and jamb batten covers, mitering corners.

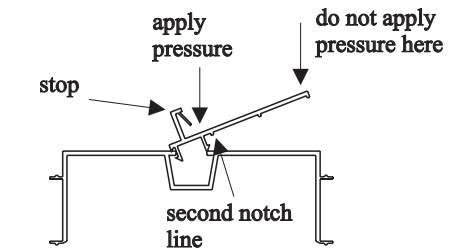

Helpful hint: A rag dampened with household detergent and rubbed over the securing ribs on the lower side will assist with installation

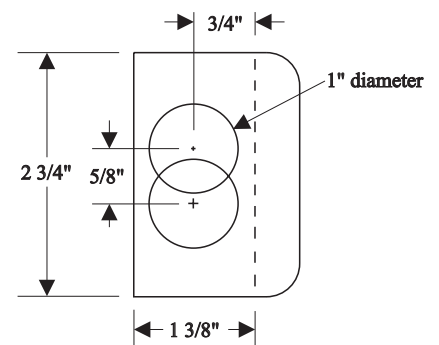

9. ALUMINUM WINDOW FRAMES

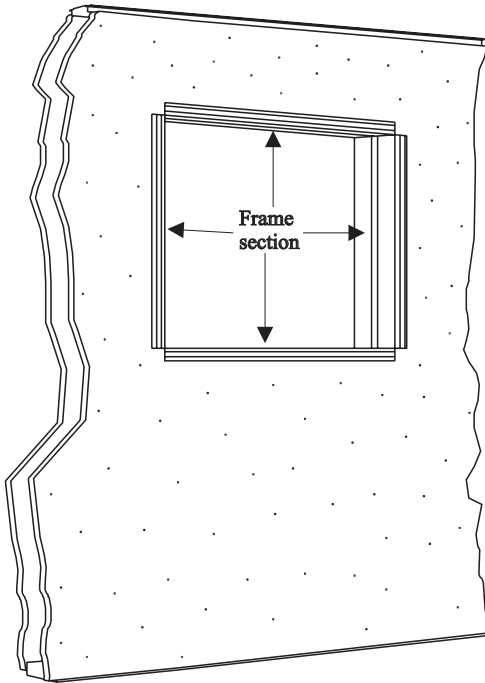

Partial height window

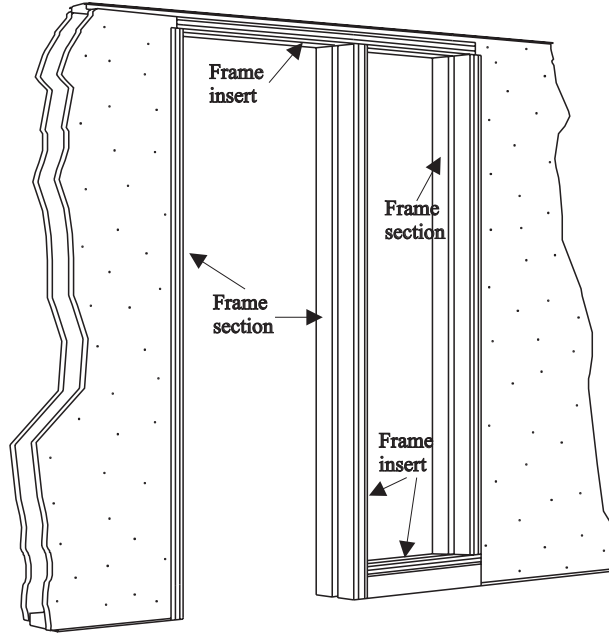

Full height door with sidelight

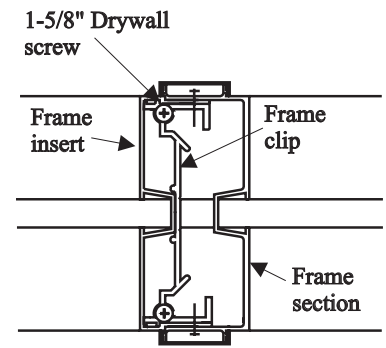

Detail of glazed post

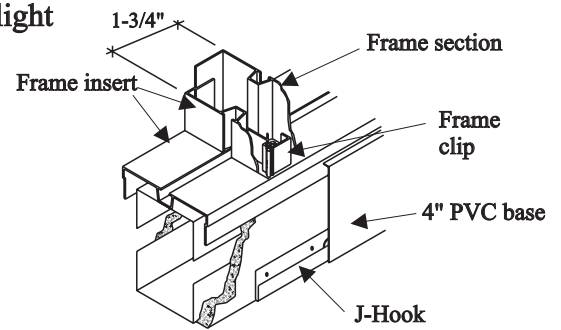

Glazed post at base sill

Installation Steps

1. Cut sill and header so they are fairly tight in width to the rough opening jambs. Install but do not fasten the sill and header.
2. Measure and cut jambs to appropriate length. Install but do not fasten.
3. Level and fasten the sill.
4. Square and fasten the jambs.
5. Bring header down, square and fasten. If full height frame, use frame clip on header, fastening frame insert and frame section @ 24" O.C.

NOTE: GLASS SIZE
Glass dimensions should be 1/8" less than the height, and 7/16" more than the width of the aluminum frame faces.

Glass Installation

1. Place wood or rubber spacers in sill channel.
2. Place glass stop on top of glass before installing.
3. Slide the glass into one of the jamb channels, then back into the other.
4. Lower the glass into the sill channel and center it between the jambs.
5. Push the glass stop into the header channel.
6. Install glazing beads along the sides and bottom to finish.

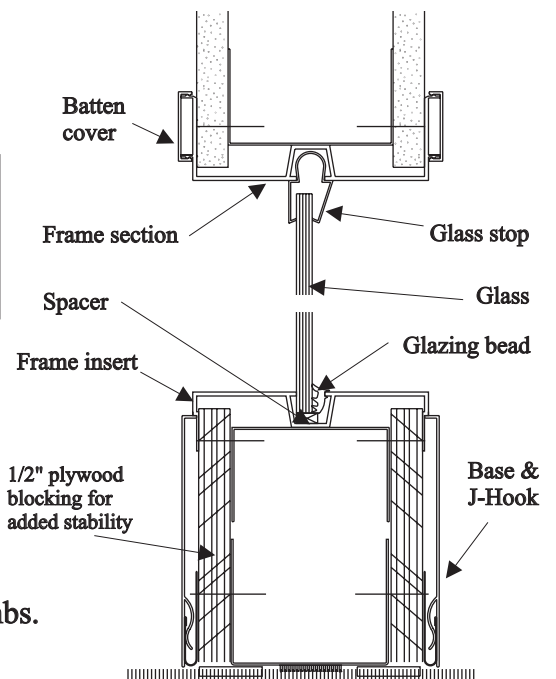

Section drawing of partial height window

10. FINISHING TOUCHES

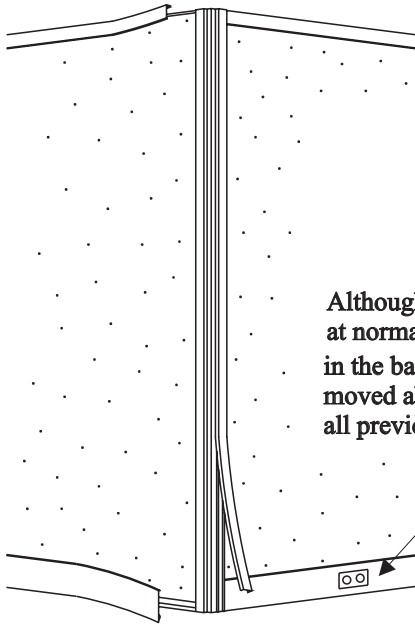

NOTE:

Although electrical outlets can be installed at normal height above the floor, installation in the base is best because when panels are moved about at a later date the base covers all previous outlet holes in the panels.

Ceiling trim, PVC base, and batten covers on a surface mounted corner.

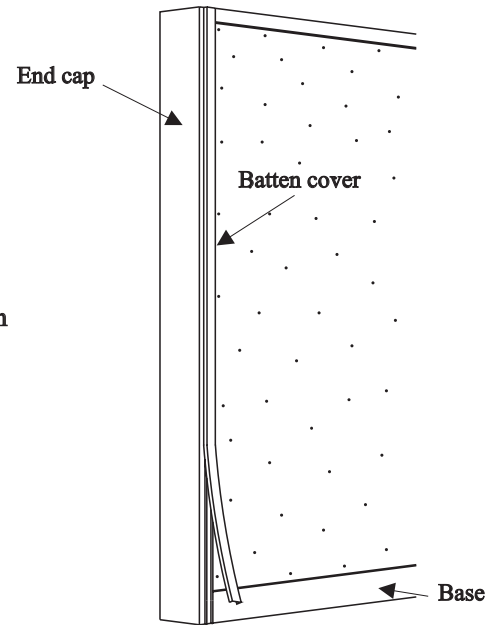

Wall end using aluminum terminal frame with batten covers.

Note:

Surface mounted corners are installed continuous from finished floor to top of wall. The base and ceiling trims butt up against this vertical trim. Surface mounted batten covers used at other locations such as at wall starts and door frames also run to the floor with the base trim terminating against them.

J-hook

The base J-hook should be installed along the floor line. Cut excess J-hook using tin snips.

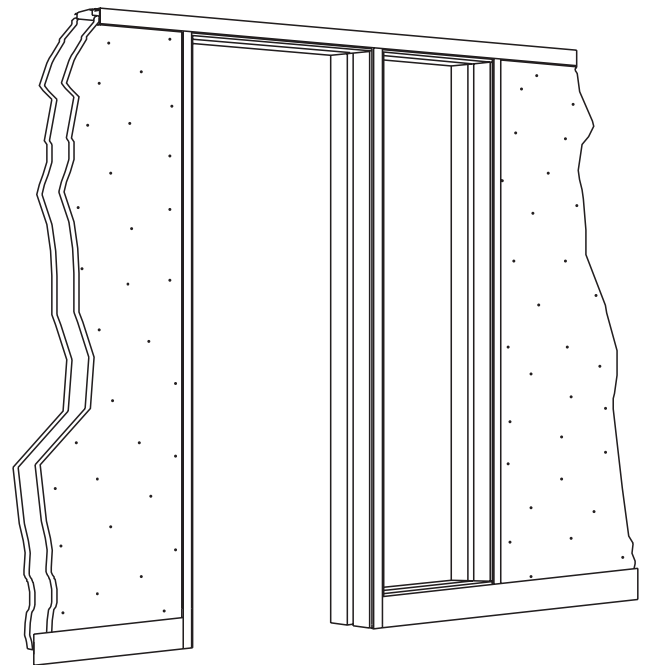
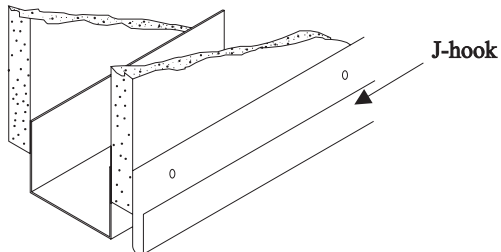

Ceiling trim, PVC base, and batten covers for door with full height window.